

503  
SENTRY



Constructed of solid aluminum bars this unique design makes a strong design statement. Whether used on brick or on smooth surfaces the fixture will dramatically enhance the aesthetics of the building.

# 503 SENTRY

TYPE

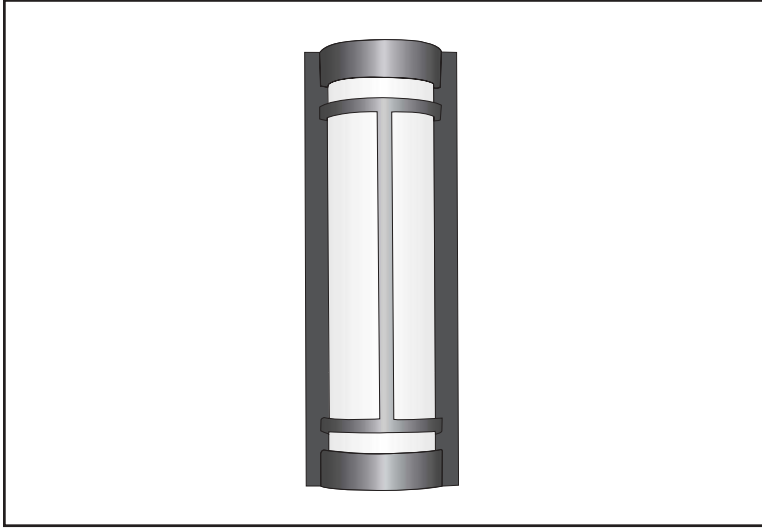

PROJECT: \_\_\_\_\_

LOCATION: \_\_\_\_\_

## FEATURES

- Solid aluminum bar stock makes for an extremely rigid fixture.
- The integration of 2", 1 1/4" and 3/4" bars blends in seamlessly for a very unique look.
- Electronic multi-volt (120/277) ballast is standard (0 degree F starting temperature)
- All parts treated with a five stage phosphate bonding process before being treated with a long lasting powder coat finish.
- Ability to lengthen fixture and add or subtract bars.
- Listed and approved for **wet locations**.
- No visible fasteners.
- Manufactured in the USA.
- Meets ADA requirements.

## DIMENSIONS

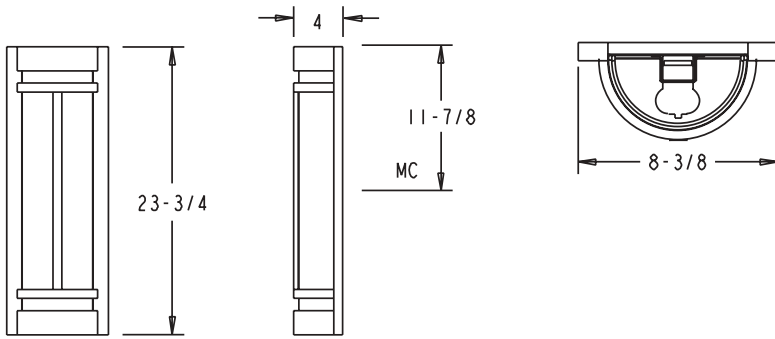

## ORDERING INFORMATION / OPTIONS EXAMPLE: 503-2BX27-BLK

503

### MODEL

503 - Sentry

### LAMP

2BX27 - (2) 27W LONG TWIN TUBE CF  
Consult factory for other available lamps.

### HOUSING FINISH

WHT - White  
BLK - Black  
SAL - Silver  
BRZ - Bronze  
Consult factory for other finishes.

### OPTIONS

BL - Bottom Lens  
TC - Top Aluminum Cover  
BC - Bottom Aluminum Cover  
Lamp - Lamp provided, please specify color temperature

**Indessa**  
Lighting

3808 N SULLIVAN RD, BLDG 12, STE 5 • SPOKANE, WA • 99216  
PHONE: 509.924.0243 • FAX: 509.924.2607 • www.indessa.com



Indessa Lighting reserves the right to make design revisions without prior notice.

OW-1.05