

469  
MERIDIA



With two luminous half cylinders jetting from the center body, this luminaire makes a strong visual impact. The luminous shields sit slightly off from the wall creating a floating appearance, adding to the mystery of the fixture.

# 469 MERIDIA

TYPE

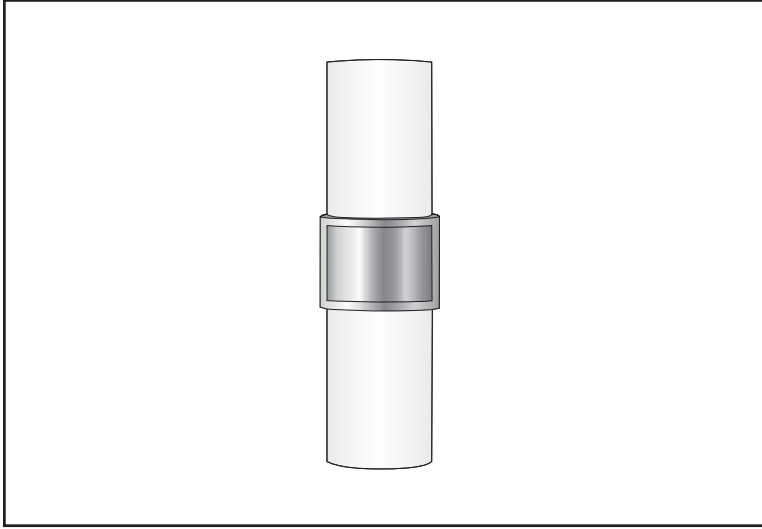

PROJECT: \_\_\_\_\_

LOCATION: \_\_\_\_\_

## FEATURES

- An intriguing luminaire that is perfect for hallways and doorways.
- Proper positioning of the lamp source allows the lens to be uniformly illuminated.
- A simplistic design allows the luminaire to be very efficient allowing the majority of light to reach the desired surface.
- Lens sits away from the wall by  $\frac{5}{8}$ " , providing a floating appearance.
- Electronic multi-volt (120/277) ballast is standard.
- Meets all ADA requirements.
- Manufactured in the USA.

## DIMENSIONS

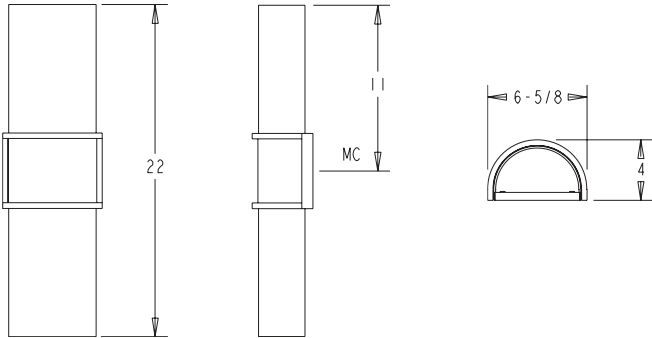

## ORDERING INFORMATION / OPTIONS EXAMPLE: 469-2CFQ26-BLK

# 469

### MODEL

469 - Meridia

### LAMP

2CFQ13 - (2) 13W QUAD TUBE CF (G24Q-1 BASE)  
 2CFQ18 - (2) 18W QUAD TUBE CF (G24Q-2 BASE)  
 2CFQ26 - (2) 26W QUAD TUBE CF (G24Q-3 BASE)  
 2CFT26 - (2) 26W TRIPLE TUBE CF (GX24Q-3 BASE)  
 Consult factory for other available lamps.

### HOUSING FINISH

WHT - White  
 BLK - Black  
 SAL - Silver  
 BRZ - Bronze  
 Consult factory for other finishes.

### OPTIONS

DL - Damp label  
 Lamp - Lamp provided,  
 please specify color  
 temperature

# Indessa Lighting

10502 EAST MONTGOMERY, SUITE 4 • SPOKANE, WA • 99206  
 PHONE: 509.924.0243 • FAX: 509.924.2607 • www.indessa.com



Indessa Lighting reserves the right to make design revisions without prior notice.

IW-11